

# Quantos Automated Dosing

## Liquid Module

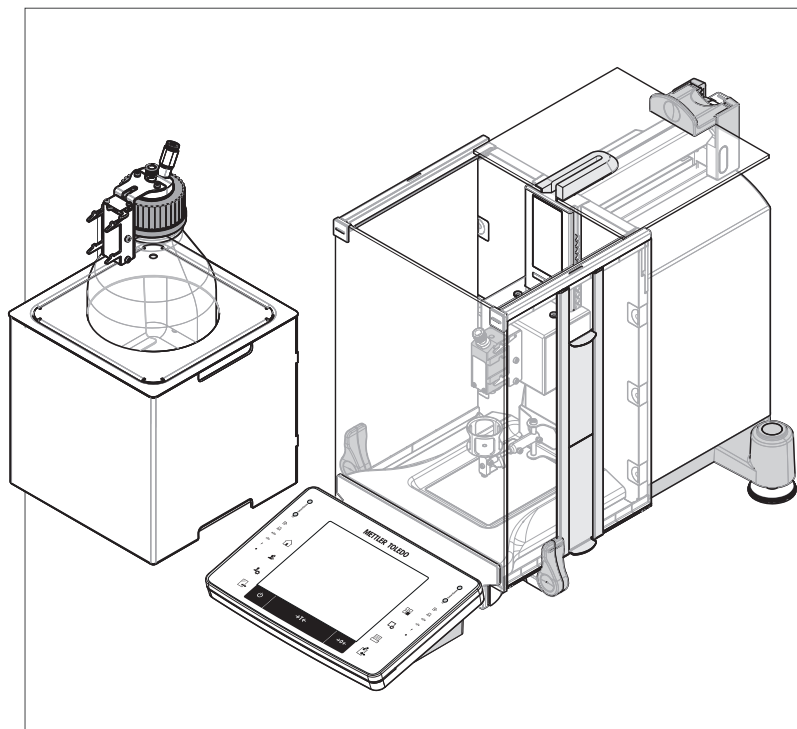

METTLER TOLEDO



## Overview Liquid module

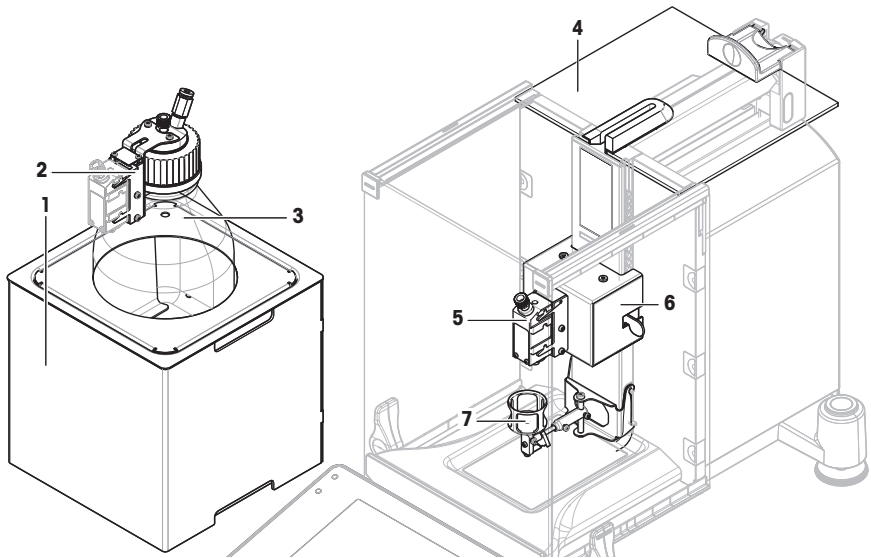

### Legend Liquid Module

Pump module with bottle		Liquid kit with liquid dosing head	
1	Pump module (QL2)	4	Top glass liquid
2	Liquid dosing head support (QLL1000)	5	Liquid dosing head (QL001)
3	Bottle	6	Liquid kit (QLX45)
		7	ErgoClip vial

## 1 Safety Information

- Read and understand the instructions in this manual before using the device.
- Keep this manual for future reference.
- Include this manual if you pass on the device to other parties.

If the device is not used according to the instructions in this manual or if it is modified, the safety of the device may be impaired and Mettler-Toledo GmbH assumes no liability.

### 1.1 Definitions of signal words and warning symbols

Safety notes contain important information on safety issues. Ignoring the safety notes may lead to personal injury, damage to the instrument, malfunctions and false results. Safety notes are marked with the following signal words and warning symbols:

#### Signal words

##### WARNING

A hazardous situation with medium risk, possibly resulting in death or severe injury if not avoided.

##### CAUTION

A hazardous situation with low risk, resulting in minor or moderate injury if not avoided.

##### NOTICE

A hazardous situation with low risk, resulting in damage to the instrument, other material damage, malfunctions and erroneous results, or loss of data.

## Warning symbols



Electrical shock



Toxic substance



Explosion



Inflammable substance



Bruising



General hazard: read the User Manual or the Reference Manual for information about the hazards and the resulting measures.



Notice

## 1.2 Product-specific safety notes

### Intended use

This dosing system is designed to be used in analytical laboratories by trained staff. The dosing system is intended for weighing and dosing powder or liquid samples.

Any other type of use and operation beyond the limits of use stated by Mettler-Toledo GmbH without consent from Mettler-Toledo GmbH is considered as not intended.

### Responsibilities of the instrument owner

The instrument owner is the person holding the legal title to the instrument and who uses the instrument or authorizes any person to use it, or the person who is deemed by law to be the operator of the instrument. The instrument owner is responsible for the safety of all users of the instrument and third parties.

METTLER TOLEDO assumes that the instrument owner trains users to safely use the instrument in their workplace and deal with potential hazards. METTLER TOLEDO assumes that the instrument owner provides the necessary protective gear.

### Protective equipment



Chemical-resistant gloves



Gloves



Lab coat

### Safety notes



#### **WARNING**

##### **Death or serious injury due to electric shock**

Contact with parts that carry a live current can lead to death or injury.

- 1 Only use the approved METTLER TOLEDO power supply cable and AC/DC adapter with a current-limited SELV output.
- 2 Connect the power cable to a grounded power outlet, ensure correct polarity.
- 3 Keep all electrical cables and connections away from liquids and moisture.
- 4 Check the cables and power plug for damage and replace damaged cables and power plugs.



### **⚠ WARNING**

#### **Injury and/or damage due to hazardous substances**

Chemical, biological or radioactive hazards can be associated with the substances processed by the instrument. During dosing procedures, small amounts of the dosed substance may become airborne and penetrate the instrument or contaminate its surroundings.

The substance characteristics and related hazards is the full responsibility of the instrument owner.

- 1 Be aware of possible hazards associated with the substance and take adequate safety measures, e.g., those stated on the safety data sheet provided by the manufacturer.
- 2 Make sure that every instrument part in contact with the substance will not get altered or damaged by the substance.



### **⚠ WARNING**

#### **Injury and/or damage due to reacting, flammable, or explosive substances**

During the dosing procedure, substances could be combined and cause an exothermic reaction or explosion. This includes powders, liquids, and gases. It may lead to serious injuries and significant material damage.

The sample characteristics and related hazards is the full responsibility of the instrument owner.

- 1 Be aware of possible hazards associated with reacting, flammable, or explosive substances.
- 2 Ensure a working temperature low enough to prevent the formation of flames or an explosion.



### **⚠ WARNING**

#### **Injury or death due to toxic substances**

If you use toxic, explosive, or flammable liquids with the pump module, the exhaust air will be contaminated.

- Connect a tube to the exhaust air outlet to collect the contaminated air.



### **⚠ WARNING**

#### **Injury and/or damage due to reacting substances**

When pressure is released from the bottle, the air/gas in the bottle moves back towards the pump module. The air/gas coming from the coupled outlets mixes in the pump module. Molecules of the substances in the various bottles can get in contact through this contaminated air/gas.

- 1 Do not connect bottles with incompatible liquids to the same pump module simultaneously.
- 2 Before connecting a second, incompatible liquid to the pump module, disconnect the first bottle and purge the pump with clean air/gas.



### **⚠ WARNING**

#### **Injury and damage to pump or bottle due to high pressure**

High pressure from external gas can damage the pump or the bottle.

- 1 Use a regulator on the external gas line.
- 2 Ensure that the pressure of the external gas does not exceed 0.2 bar (2.9 psi).



### **⚠ CAUTION**

#### **Injury due to splashing liquids**

If the pressure in the bottle is not released, liquid might splash when removing the micro dosing valve, opening the bottle, or removing the liquid tube.

- Always release pressure by switching off the instrument before removing the micro dosing valve, opening the bottle, or removing the liquid tube.



### CAUTION

#### Injury due to moving parts

- Do not reach into the working area while parts of the instrument are moving.



### CAUTION

#### Injury due to sharp objects or broken glass

- Instrument components, e.g., glass, can break and lead to injuries.
- Always proceed with focus and care.



### NOTICE

#### Damage to the instrument due to the use of unsuitable parts

- Using unsuitable parts with the instrument can damage the instrument or cause it to malfunction.
- Only use parts from METTLER TOLEDO that are intended to be used with your instrument.



### NOTICE

#### Damage to the device

The device contains no user-serviceable parts.

- 1 Do not open the device.
- 2 In the event of problems, please contact a METTLER TOLEDO representative.



### NOTICE

#### Damage to the instrument due to inappropriate cleaning methods

The instrument can be damaged by certain cleaning agents, solvents, or abrasives. If liquids enter the housing, they can damage the instrument.

- 1 Only use a wet cloth with water and a mild detergent to clean the instrument or terminal.
- 2 Wipe off any spills immediately.
- 3 Make sure that no liquid penetrates the instrument.

## 2 Design and Function

### 2.1 Dosing head

#### Liquid dosing head

This is the standard head for liquid dosing. It is used together with pump module and bottle.

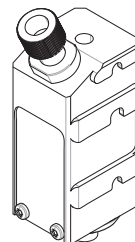

#### Functional description

As soon as a head is inserted, the instrument automatically reads the data of the head. In addition, the instrument performs automatic adjustments concerning the **Dosing steps**, automatic door operation and other instrument settings.

When no dosing head is installed the instrument will replace head-specific information with factory settings.

## 2.2 Data stored in the dosing head's RFID

Every dosing head is equipped with an integrated RFID tag (1) which stores and exchanges data with the instrument.

The following data is stored in the RFID tag of the head:

- **User data**
- This block holds information about the substance such as the name of the substance, the filling and expiry dates, the quantity, etc. This data can be edited by the user at any time and should be entered before using a new head for the first time to have the data available for reports and labels.

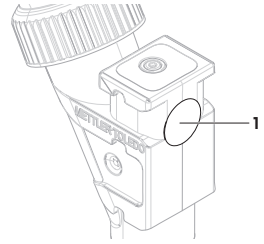

### 3 Installation and Putting into Operation



This User Manual is a brief instruction that provides information to handle with the first steps of the instrument in a safe and efficient manner. Personnel must have carefully read and understood this manual before performing any tasks.

For full information, always consult the Reference Manual (RM).

► [www.mt.com/Liquid-Module-RM](http://www.mt.com/Liquid-Module-RM)

The instrument is installed by METTLER TOLEDO service technicians. This includes the wiring as well as the configuration of the interfaces and peripherals.

#### 3.1 Scope of delivery



##### NOTICE

##### Damage to the instrument due to the use of unsuitable parts

Using unsuitable parts with the instrument can damage the instrument or cause it to malfunction.

- Only use parts from METTLER TOLEDO that are intended to be used with your instrument.

##### QLX45 liquid kit

- Liquid kit QLX45
- Top glass liquid
- ErgoClip vial
- SmartGrid round
- Vial adapter 4 pcs
- MinWeigh door
- Screwdriver torx T8
- RS232C-cable
- Power supply
- Cable conduct
- Cable clip (cable conduct closure)
- User Manual

##### QLL standard kit for bottles

- Liquid head QL001
- Pressure-resistant bottle
- Bottle cap (GL45) with fitting and support
- Micro dosing valve tool
- Spare part set (incl. filter, sealing ring, fastening nut)
- Liquid tube
- Air tube

##### QL2 pump module

- Pump module
- Liquid side doors for Q2
- Muffler
- Bottle holder
- Drip pan
- CAN-cable

##### Recommended options

- Ethernet Option
- Ethernet / RS232 (Netcom kit)
- AntiStatic kit
- Cable box

#### 3.2 Selecting the location

An optimal location will ensure accurate and reliable operation of the instrument. The surface must be able to safely take the weight of the instrument when fully loaded. The following local conditions must be observed:



- The instrument must only be used indoors and up to a maximum altitude of 4000 m above sea level.
- Before switching on the balance, wait until all parts are at room temperature (+5 to 40 °C). The humidity must be between 10% and 80% non-condensing.
- The power plug must be accessible at all times.
- Firm, horizontal and vibration-free location.
- Avoid direct sunlight.
- No excessive temperature fluctuations.
- No strong drafts.

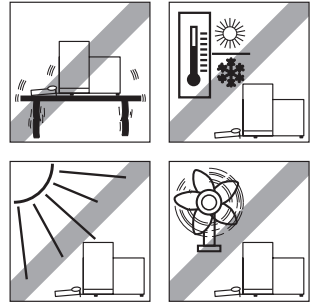

If the instrument is not horizontal at the outset, it must be leveled during commissioning.

### 3.3 Assembling the liquid module



Assemble the balance according to your XPE Operating Instructions.

► [www.mt.com/library](http://www.mt.com/library)

- 1 Remove top glass (1) by sliding it backwards and pulling it upwards (2) carefully.

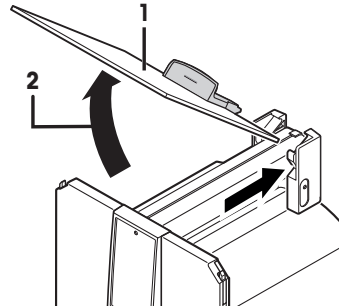

- 2 Insert the liquid kit (1), pull 2 levers (2) towards you and slide liquid kit onto the rack.

**Note**

CAN-connector is on bottom of liquid kit.

- 3 To fix position of liquid kit, release 2 levers (2) and move liquid kit slightly.

- ⇒ Liquid kit locks down.
- ⇒ Liquid kit is mounted.

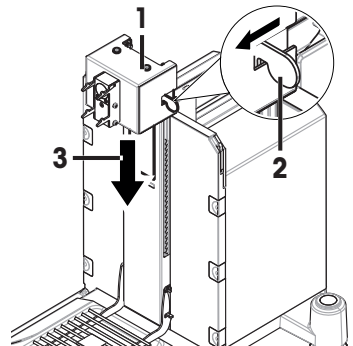

- 4 Insert the top glass liquid (1) into the rear guide.
- 5 Carefully fold top glass liquid (2) downwards.

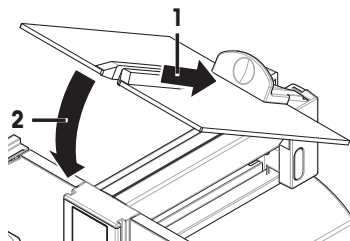

### 3.4 Assembling pump module and bottle



#### **WARNING**

##### **Injury and damage to pump or bottle due to high pressure**

High pressure from external gas can damage the pump or the bottle.

- 1 Use a regulator on the external gas line.
- 2 Ensure that the pressure of the external gas does not exceed 0.2 bar (2.9 psi).

- Assemble pump module and bottle according to figure.

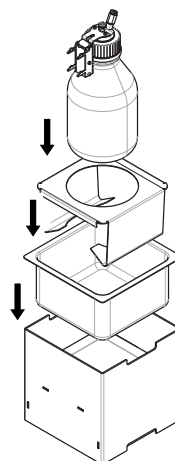

### Inserting and removing a liquid dosing head in and from the liquid dosing head support



#### **CAUTION**

##### **Injury due to splashing liquids**

If the pressure in the bottle is not released, liquid might splash when removing the micro dosing valve, opening the bottle, or removing the liquid tube.

- Always release pressure by switching off the instrument before removing the micro dosing valve, opening the bottle, or removing the liquid tube.

- 1 Insert liquid dosing head in the liquid dosing head support.

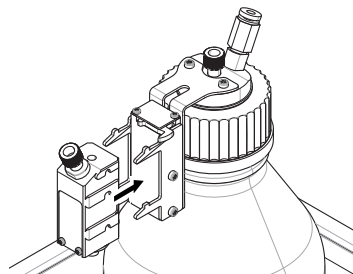

- 2 To remove liquid dosing head from the liquid dosing head support, pull the catch (1) to the front and remove liquid dosing head (2).

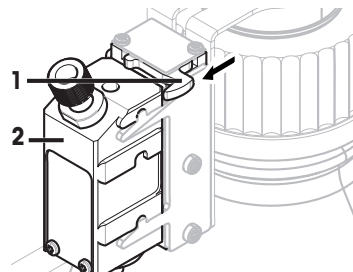

### 3.5 Installing liquid dosing head on liquid kit

#### Installing liquid dosing head on liquid kit

- 1 Slide the liquid dosing head (1) onto the liquid kit (2) until it comes to a stop.
- 2 Press it down slightly until it is properly seated in the holding pins.  
**Important**  
Check that dosing head is inserted correctly.  
If there is just a small gap between dosing head and its support, press it down again.
- 3 Thread the liquid tube through slot in Quantos top glass.

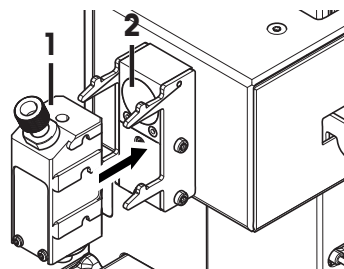

#### Removing liquid dosing head from liquid kit

- To remove the liquid dosing head, press it slightly upwards and remove it to the front.

## 3.6 Connecting the tubes

### Connectors of pump module

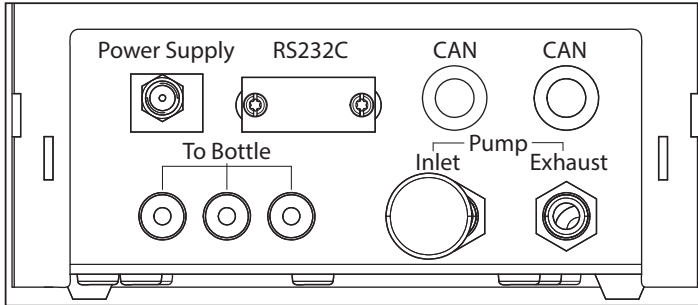

### Tubes definition

The thinner tube is used for transporting liquid from the bottle to the liquid dosing head. The slightly bigger tube is used for pumping air into the bottle. By adding air, pressure rises in the bottle. When pressure reaches min. 0.3 to max 0.5 bar (4.4 to 7.2 psi) the micro dispensing valve in the dosing head opens and liquid can ascend the liquid tube. The two tubes are further referred to as liquid tube and air tube.

### Connecting the liquid tube

- The liquid dosing head is inserted in the liquid dosing head support.

- 1 Place the sealing ring (1) on the table with the wider end on the table.
- 2 Take the end of the liquid tube and press it into the sealing ring.  
⇒ This is the dosing-head end of the tube. The opposite end is the bottle end.
- 3 Thread the fastening nuts (2), paying attention to the orientation.
- 4 Thread the sealing ring (3) from the bottle end of the tube (slide until 220 mm from the end using the micro dosing valve tool). Pay attention to the orientation.
- 5 Insert the dosing-head end of the tube (4) in the dosing head (5).
- 6 Tightly fasten the fastening nut to the dosing head.
- 7 Insert the bottle end of the tube through the corresponding hole in the bottle cap (6). The tube should reach the bottom of the bottle.
- 8 Attach the suction filter to the bottle end of the tube.
- 9 Screw the cap to the bottle.

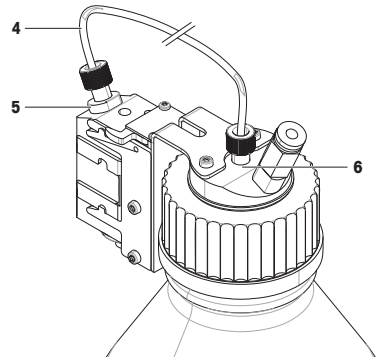
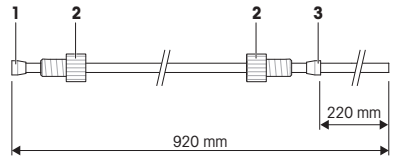

## Connecting the air tube



### ⚠ WARNING

#### Injury and/or damage due to reacting substances

When pressure is released from the bottle, the air/gas in the bottle moves back towards the pump module. The air/gas coming from the coupled outlets mixes in the pump module. Molecules of the substances in the various bottles can get in contact through this contaminated air/gas.

- 1 Do not connect bottles with incompatible liquids to the same pump module simultaneously.
- 2 Before connecting a second, incompatible liquid to the pump module, disconnect the first bottle and purge the pump with clean air/gas.



### NOTICE

#### Damage to tube connectors due to mishandling

If the tubes are not removed correctly, the connectors and therefore the pump module can be damaged.

Wrongly cut tubing can result in leaking connections.

- 1 To remove the tubes, press down the ring on the connector and pull out the tube carefully.
- 2 Cut the tubes with a tube cutter.

- 1 Connect the air tube (8) to the air inlet of the bottle (7)
- 2 Connect the other end of the air tube to the air outlet of the pump module (9).
- 3 Insert the muffler into the air inlet of the pump module (10) to absorb the noise.

When a tube is connected to the air outlet of the pump, the valve of the air outlet opens. Never leave a tube that is connected to the air outlet unconnected at the other end because pressure can not be built up.

You can connect up to 3 bottles to the pump module.

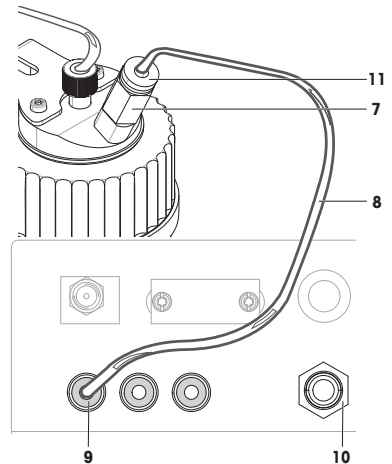

### Removing the air tube

- 1 Remove the air tube (8) from the bottle by firmly pressing down the ring (11) at the air inlet (7).
- 2 If necessary, remove the air tube from the pump module by pushing the ring (9).

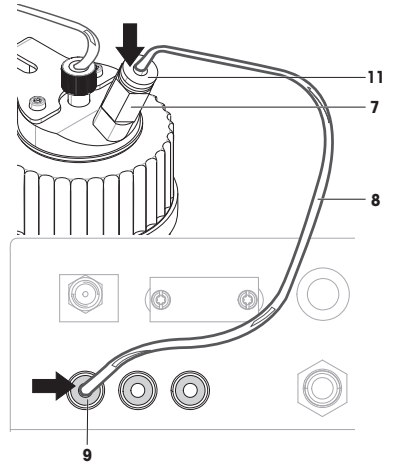

### Using the pump with external gas



#### **WARNING**

##### **Injury and damage to pump or bottle due to high pressure**

High pressure from external gas can damage the pump or the bottle.

- 1 Use a regulator on the external gas line.
- 2 Ensure that the pressure of the external gas does not exceed 0.2 bar (2.9 psi).

- 1 The liquid can be protected by feeding an external gas, e.g., nitrogen, to the pump. Make sure that the pressure of the external gas does not exceed 0.2 bar (2.9 psi).
  - 2 Remove the muffler from the air inlet of the pump module (10).
  - 3 Connect the tube to the air inlet of the pump module (10).
- Note**  
Outer tube diameter: 6 mm  
Pressure range: 0.1 to 0.2 bar (1.5 to 2.9 psi)

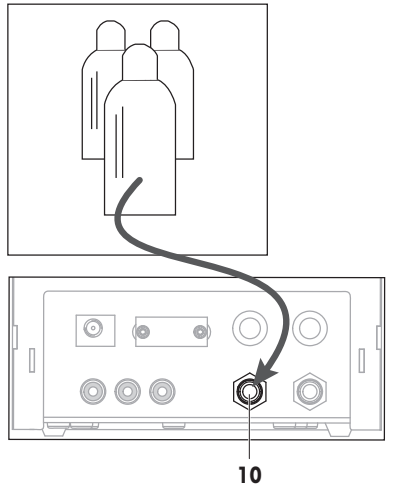

## Contaminated air by using toxic, explosive or flammable liquids



### WARNING

#### Injury or death due to toxic substances

If you use toxic, explosive, or flammable liquids with the pump module, the exhaust air will be contaminated.

- Connect a tube to the exhaust air outlet to collect the contaminated air.

- Connect a tube to exhaust air outlet (12) to collect the contaminated air into a safe container.

#### Note

Outer tube diameter: 6 mm

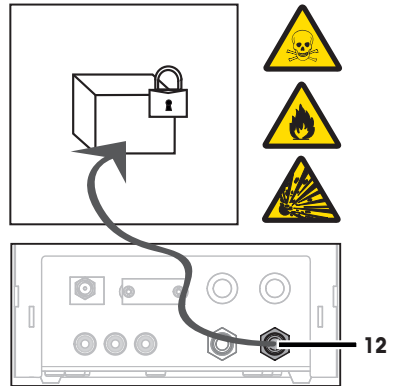

## 3.7 Wiring the liquid module



### WARNING

#### Death or serious injury due to electric shock

Contact with parts that carry a live current can lead to death or injury.

- 1 Only use the approved METTLER TOLEDO power supply cable and AC/DC adapter with a current-limited SELV output.
- 2 Connect the power cable to a grounded power outlet, ensure correct polarity.
- 3 Keep all electrical cables and connections away from liquids and moisture.
- 4 Check the cables and power plug for damage and replace damaged cables and power plugs.

#### Note

The balance is supplied with an AC/DC adapter and a country-specific power cable. The AC/DC adapter is suitable for use with the following voltage range:

100 – 240 V AC, 50/60 Hz.

#### Important

Wire the components before turning the balance on.

After turning the balance on, if the message **Wrong head type mounted** appears, check wires.

Make sure you connect CAN-cables before connecting power supplies.

## Connectors of pump module

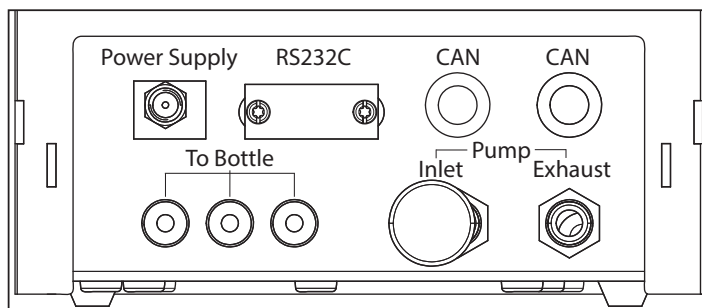

Power supply and RS232C-connector are covered with a faceplate. Remove faceplate.

- 1 Connect pump module with liquid kit via CAN-cable.  
There are 2 CAN-connectors on the pump module. There is no preference which one to take.
- 2 Remove left side glass and exchange one clip with the cable clip included in the scope of delivery.
- 3 Guide CAN-cable through cable clip and insert left side glass.

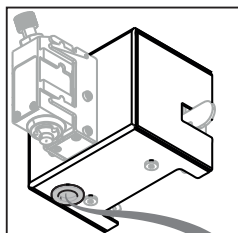

- 4 Connect pump module with balance via standard RS232C-cable.  
⇒ Liquid module is connected.

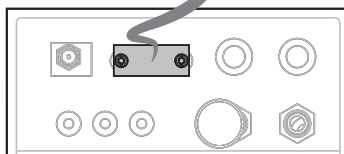
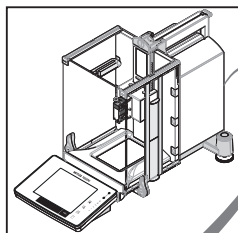
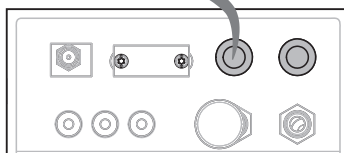



- 1 Connect power cable of liquid module to power socket and local power supply.
- 2 Connect power cable of balance to power socket and local power supply.

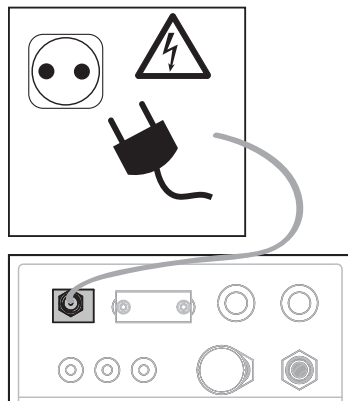

## 4 Operation

### 4.1 Basic operation settings



Refer to your XPE Operating Instructions for further information on settings and parameters.

► [www.mt.com/library](http://www.mt.com/library)

**Navigation:** > **Liquid module > Mounted**

If you dose liquid for the first time, or after a master reset, check following settings:

Configure your settings in the following menu:

- Dosing must be chosen as application: > **Dosing**
- Liquid module must be defined as mounted: > **Liquid module > Mounted**
- Powder module must be defined as unmounted: > **Powder module > Unmounted**
- RS232 device must be activated: > **System > Peripherals > RFID / Quantos > RS232 built-in**

### 4.2 Dosing liquid

- Liquid dosing head is installed.
- Weighing pan is empty.
- If required, ErgoClip is installed.

1 Tap **Start > Liquid dosing**.

2 Enter **User ID** and confirm with **OK**.

3 **Note**

The **Sample ID** is not mandatory and the instrument does not check whether or not it is unique.

Enter **Sample ID** and confirm with **OK**.

4 Enter the amount **Target liquid [g]** required and confirm with **OK**.

5 Place sample vessel on weighing pan or ErgoClip and confirm with **OK**.

6 Lower position of dosing head until it is about 1 cm to 2 cm above the sample vessel and confirm with **OK**.

7 **Note**

To abort dosing during process, tap **C**.

Check if all necessary adjustments are completed:

To abort procedure, tap **No**.

To start dosing, tap **Yes**.

⇒ Pressure builds up.

⇒ Instrument doses liquid.

⇒ The results are being displayed.

8 To finish dosing process, confirm with **OK**.

**Note**

- Bubbles in the tube do not impair the result, because the target result is weighed.
- If you dose liquids that might crystallize, clean the dosing head from time to time.

**Note**

**See** Liquid Module Reference Manual for further information on dosing applications.

### 4.3 Releasing pressure

If you need to release the pressure in e.g. the bottle, switch off the instrument.

**Switching Off**

- Press until **Off** appears in the display.

## Note

Do not disconnect the instrument from the power supply except if you will not be using the instrument for an extended period.

## 4.4 Handling the bottle



### CAUTION

#### Injury due to splashing liquids

If the pressure in the bottle is not released, liquid might splash when removing the micro dosing valve, opening the bottle, or removing the liquid tube.

- Always release pressure by switching off the instrument before removing the micro dosing valve, opening the bottle, or removing the liquid tube.

### Filling the bottle

The suction filter (1) has to be covered with liquid at all times. Before the suction filter gets dry, refill the bottle.

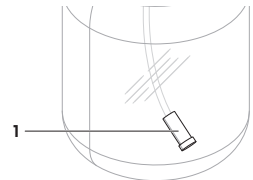

- Pressure is released.
- 1 Unscrew cap.
  - 2 Fill in the liquid. (max. is shown on bottle, e.g., 1000 ml).

#### Note

Do not exceed the maximum. The air above the liquid is necessary for dosing.

- 3 Screw cap on.
- 4 Check that the cap is tight.

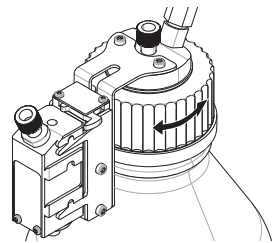

### Changing the liquid of the bottle

You have only one cap with dosing head and want to change the liquid:

- Pressure is released.
- 1 Unplug air tube.
  - 2 Unscrew cap.
  - 3 Remove the suction filter.
  - 4 If the cap needs to be cleaned, remove the air tube.  
Unscrew the fastening nuts from the cap and the dosing head.  
Rinse the cap with the appropriate solvent or liquid.  
Insert both ends of the liquid tube at the dosing head and the cap, respectively.
  - 5 If the liquid tube needs to be cleaned with a solvent, fill the bottle with the appropriate solvent.  
Screw the cap on the bottle.  
Insert the air tube on the cap.  
Purge using the **Purge** function.  
Unscrew the cap.  
Dispose of the remainder of the solvent.
  - 6 Attach a new suction filter.
  - 7 Screw the cap on bottle with new liquid.
  - 8 Check that the cap is tight.
  - 9 Connect air tube to new bottle.

10 Purge using the **Purge** function.

### Changing a bottle

If you have more than one bottle equipped with cap and dosing head:

- Pressure is released.
- 1 Install dosing head on dosing head support at the bottle.
  - 2 Unplug air tube by pressing ring (1) down and pulling tube (2) out carefully at the same time.
  - 3 To seal the bottle, insert pin into air tube fitting.
  - 4 Take the new bottle.
  - 5 Connect air tube to new bottle.
  - 6 To continue dosing with the new bottle, install dosing head.

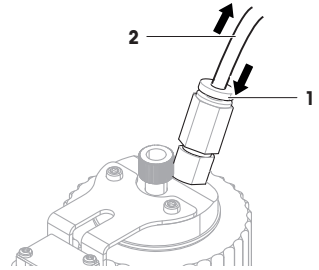

## 5 Technical Data

### 5.1 General data

#### Power supply

AC/DC adapter:

Primary: 100 – 240 V, -15%/+10%, 50/60 Hz

Secondary: 12 V DC  $\pm 3\%$ , 2.5 A (with electronic overload protection)

Cable for AC/DC adapter:

3-core, with country-specific plug

Power consumption (liquid module):

12 V DC, 2.0 A

Polarity:

 with a current limited SELV (Safety Extra Low Voltage) output

#### Protection and standards

Overvoltage category:

II

Degree of pollution:

2

Protection:

Protected against dust and water

Standards for safety and EMC:

See Declaration of Conformity

Range of application:

For use in closed interior rooms only

#### Environmental conditions

Height above mean sea level:

Up to 4000 m

Ambient temperature:

5–40 °C

Relative air humidity:

Max. 80% up to 31 °C, linearly decreasing to 50% at 40 °C, noncondensing

#### Materials

Housing:

Die-cast aluminum, plastic, chrome steel and glass

## 6 Information on Standards

### FCC Rules

This device complies with Industry Canada licence-exempt RSS standard(s) and part 15 of the FCC Rules. Operation is subject to the following two conditions: (1) this device may not cause interference, and (2) this device must accept any interference, including interference that may cause undesired operation of the device.

Changes or modifications not expressly approved by the party responsible for compliance could void the user's authority to operate the equipment.

This equipment has been tested and found to comply with the limits for a Class A digital device, pursuant to part 15 of the FCC Rules. These limits are designed to provide reasonable protection against harmful interference when the equipment is operated in a commercial environment. This equipment generates, uses, and can radiate radio frequency energy and, if not installed and used in accordance with the instruction manual, may cause harmful interference to radio communications. Operation of this equipment in a residential area is likely to cause harmful interference in which case the user will be required to correct the interference at his own expense.



# GWP®

Good Weighing Practice™

---

GWP® is the global weighing standard, ensuring consistent accuracy of weighing processes, applicable to all equipment from any manufacturer. It helps to:

- Choose the appropriate balance or scale
- Calibrate and operate your weighing equipment with security
- Comply with quality and compliance standards in laboratory and manufacturing

 [www.mt.com/GWP](http://www.mt.com/GWP)

---

For more information

**Mettler-Toledo GmbH**

Im Langacher 44  
8606 Greifensee, Switzerland  
[www.mt.com/contact](http://www.mt.com/contact)

Subject to technical changes.  
© Mettler-Toledo GmbH 12/2018  
30260315D en



30260315